

ORDER FORM

POLYMAC AXES



PUSHING THE ENVELOPE

CUSTOMER INFORMATION |

Customer Name : _____	Customer Ref. No. : _____	Tel : _____
Contact : _____	Email : _____	
Customer Address : _____	Project Name : _____	

Polymac Axes redefines the expression of metal cladding through a pattern of raised lines integrated into each panel, creating a structured surface.

This surface treatment creates a unique interaction with light, generating depth, texture, and movement for a distinctive architectural signature.

Each panel format is available in 8 exclusive patterns, while corner panels are offered in 4 different pattern designs, providing a wide range of possibilities to create dynamic, customized façades.

Depending on the design intent, you may:

- select specific patterns to faithfully reproduce an architectural concept or visual;
- or choose mixed boxes including all 8 panel patterns or 4 corner panel patterns, allowing for a more random installation with an organic, rhythmic finish.

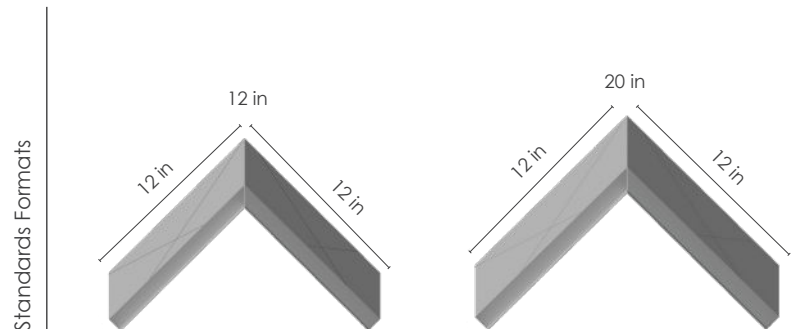
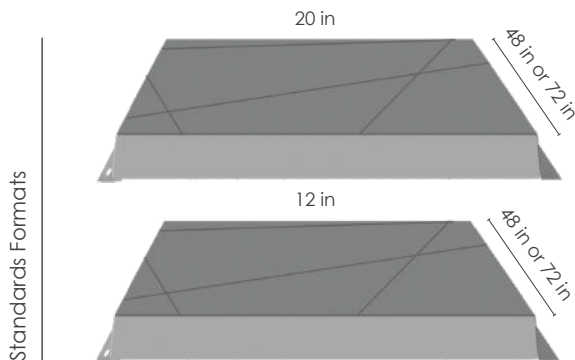

ORDER FORM

POLYMAC AXES 12" X 48"

Description	Product code	Pattern number	Code color	Qt./box 8 panels
Polymac Axes 12" x 48", 22 g	SPPA1G22.12X48	No1		
Polymac Axes 12" x 48", 22 g	SPPA2G22.12X48	No2		
Polymac Axes 12" x 48", 22 g	SPPA3G22.12X48	No3		
Polymac Axes 12" x 48", 22 g	SPPA4G22.12X48	No4		
Polymac Axes 12" x 48", 22 g	SPPA5G22.12X48	No5		
Polymac Axes 12" x 48", 22 g	SPPA6G22.12X48	No6		
Polymac Axes 12" x 48", 22 g	SPPA7G22.12X48	No7		
Polymac Axes 12" x 48", 22 g	SPPA8G22.12X48	No8		
Polymac Axes 12" x 48", 22 g	SPPAMG22.12X48	Mix (all 8 No)		

SPECIFICATIONS | POLYMAC AXES 12" X 48"

Length 48 in (1219.2 mm)	Width 12 in (304.8 mm)	Depth 1 in (25.4 mm)	Box 8 panels (12 x 48 in), 32 ft ² (3 m ²)
----------------------------	--------------------------	------------------------	---

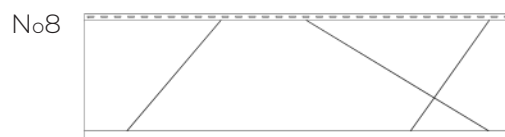
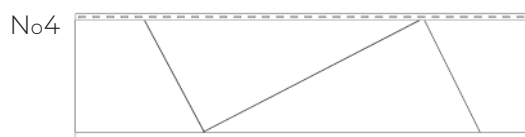
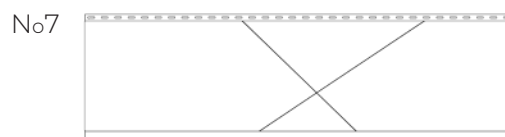
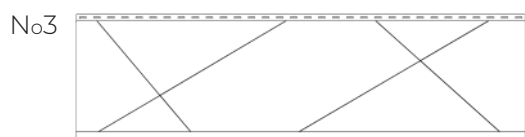
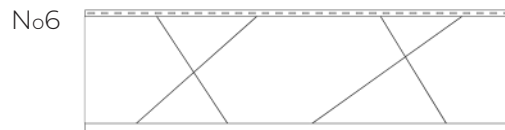
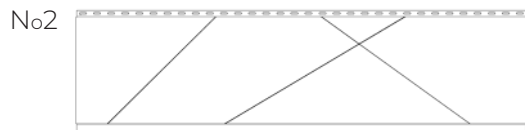
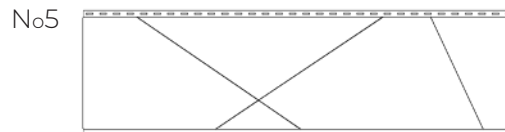
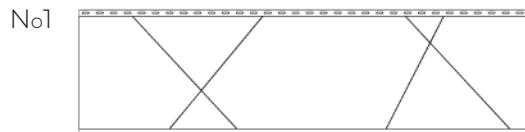

Collection	Color Code	22 g	22 g	22 g	22 g			
Signature Collection	202-Anthracite	x	203-Brushed Zinc	x	204-Smoky Quartz	x	205-Copper Bronze	x
Inspiration Collection	101-Titanium White	x	102-Titanium Black	x	103-Metallic Grey	x	104-Metallic Copper	x
	105-Slate Grey	x	106-Charcoal Grey	x	108-Autumn Blue	x		

ORDER FORM

POLYMAC AXES 12" X 72"



PUSHING THE ENVELOPE

Description	Product code	Pattern number	Code color	Qt./box 8 panels
Polymac Axes 12" x 72", 22 g	SPPA1G22.12X72	No1		
Polymac Axes 12" x 72", 22 g	SPPA2G22.12X72	No2		
Polymac Axes 12" x 72", 22 g	SPPA3G22.12X72	No3		
Polymac Axes 12" x 72", 22 g	SPPA4G22.12X72	No4		
Polymac Axes 12" x 72", 22 g	SPPA5G22.12X72	No5		
Polymac Axes 12" x 72", 22 g	SPPA6G22.12X72	No6		
Polymac Axes 12" x 72", 22 g	SPPA7G22.12X72	No7		
Polymac Axes 12" x 72", 22 g	SPPA8G22.12X72	No8		
Polymac Axes 12" x 72", 22 g	SPPAMG22.12X72	Mix (all 8 No)		

SPECIFICATIONS | POLYMAC AXES 12" X 72"

Length 72 in (1828.8 mm)	Width 12 in (304.8 mm)	Depth 1 in (25.4 mm)	Box 8 panels (12 x 72 in), 48 ft ² (4.46 m ²)
----------------------------	--------------------------	------------------------	---

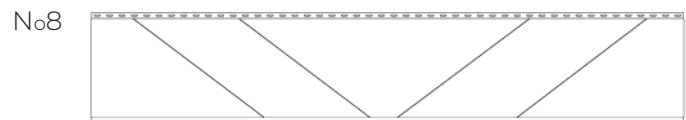
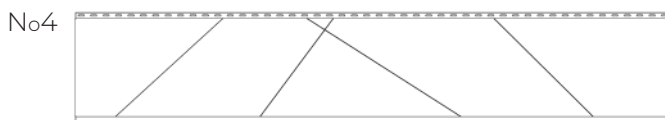
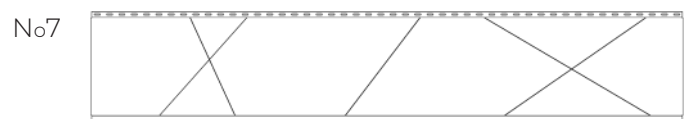
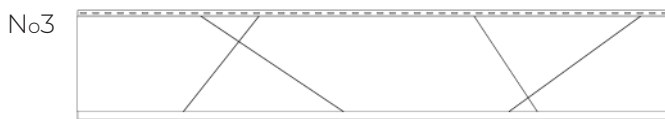
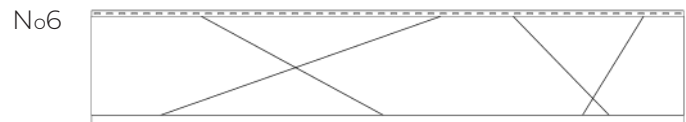
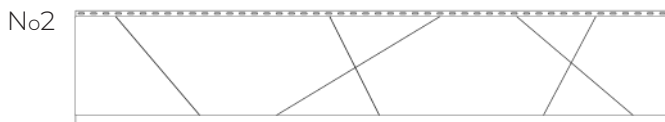
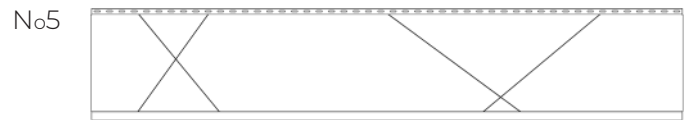
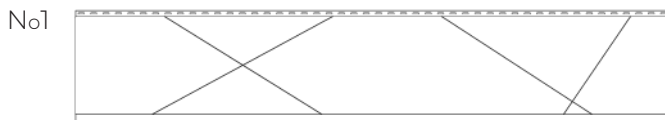

Collection	Color Code	22 g	22 g	22 g	22 g			
Signature Collection	202-Anthracite	x	203-Brushed Zinc	x	204-Smoky Quartz	x	205-Copper Bronze	x
Inspiration Collection	101-Titanium White	x	102-Titanium Black	x	103-Metallic Grey	x	104-Metallic Copper	x
	105-Slate Grey	x	106-Charcoal Grey	x	108-Autumn Blue	x		

ORDER FORM

POLYMAC AXES 20" X 48"



PUSHING THE ENVELOPE

Description	Product code	Pattern number	Code color	Qt./box 8 panels
Polymac Axes 20" x 48", 22 g	SPPA1G22.20X48	No1		
Polymac Axes 20" x 48", 22 g	SPPA2G22.20X48	No2		
Polymac Axes 20" x 48", 22 g	SPPA3G22.20X48	No3		
Polymac Axes 20" x 48", 22 g	SPPA4G22.20X48	No4		
Polymac Axes 20" x 48", 22 g	SPPA5G22.20X48	No5		
Polymac Axes 20" x 48", 22 g	SPPA6G22.20X48	No6		
Polymac Axes 20" x 48", 22 g	SPPA7G22.20X48	No7		
Polymac Axes 20" x 48", 22 g	SPPA8G22.20X48	No8		
Polymac Axes 20" x 48", 22 g	SPPAMG22.20X48	Mix (all 8 No)		

SPECIFICATIONS | POLYMAC AXES 20" X 48"

Length 48 in (1219.2 mm)	Width 20 in (508 mm)	Depth 1 in (25.4 mm)	Box 8 panels (20 x 48 in), 53.33 ft ² (4.96 m ²)
----------------------------	------------------------	------------------------	---

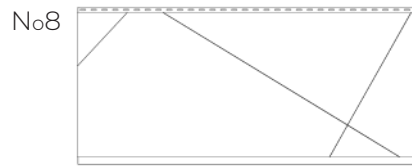
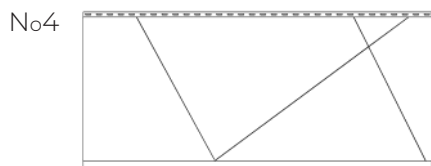
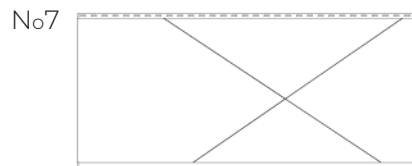
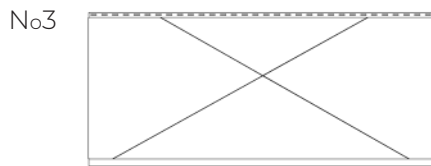
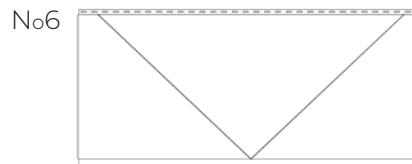
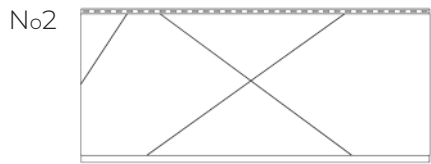
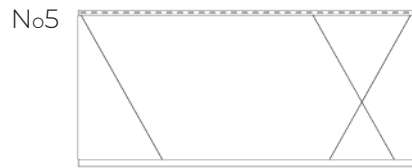
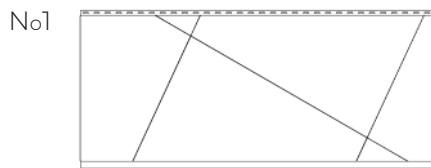

Collection	Color Code	22 g	22 g	22 g	22 g			
Signature Collection	202-Anthracite	x	203-Brushed Zinc	x	204-Smoky Quartz	x	205-Copper Bronze	x
Inspiration Collection	101-Titanium White	x	102-Titanium Black	x	103-Metallic Grey	x	104-Metallic Copper	x
	105-Slate Grey	x	106-Charcoal Grey	x	108-Autumn Blue	x		

ORDER FORM

POLYMAC AXES 20" X 72"



PUSHING THE ENVELOPE

Description	Product code	Pattern number	Code color	Qt./box 8 panels
Polymac Axes 20" x 72", 22 g	SPPA1G22.20X72	No1		
Polymac Axes 20" x 72", 22 g	SPPA2G22.20X72	No2		
Polymac Axes 20" x 72", 22 g	SPPA3G22.20X72	No3		
Polymac Axes 20" x 72", 22 g	SPPA4G22.20X72	No4		
Polymac Axes 20" x 72", 22 g	SPPA5G22.20X72	No5		
Polymac Axes 20" x 72", 22 g	SPPA6G22.20X72	No6		
Polymac Axes 20" x 72", 22 g	SPPA7G22.20X72	No7		
Polymac Axes 20" x 72", 22 g	SPPA8G22.20X72	No8		
Polymac Axes 20" x 72", 22 g	SPPAMG22.20X72	Mix (all 8 No)		

SPECIFICATIONS | POLYMAC AXES 20" X 72"

Length 72 in (1828.8 mm)	Width 20 in (508 mm)	Depth 1 in (25.4 mm)	Box 8 panels (20 x 72 in), 80 ft ² (7.44m ²)
----------------------------	------------------------	------------------------	---

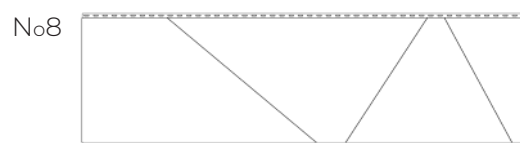
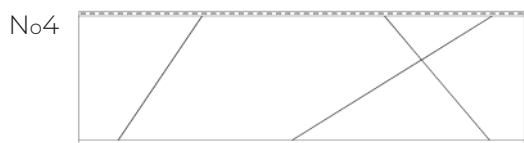
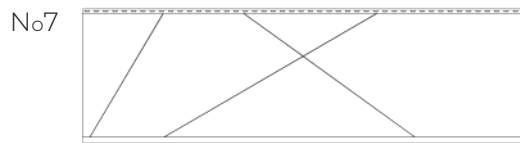
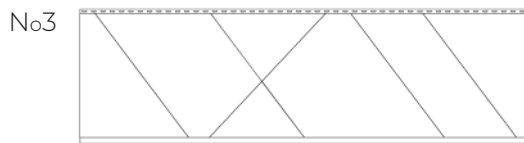
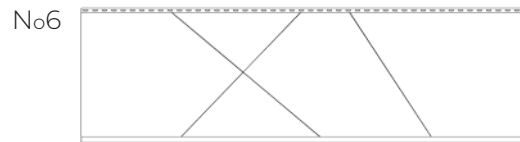
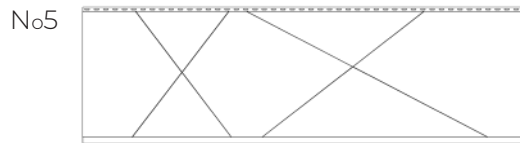
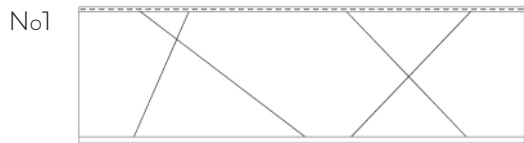

Collection	Color Code	22 g	22 g	22 g	22 g			
Signature Collection	202-Anthracite	x	203-Brushed Zinc	x	204-Smoky Quartz	x	205-Copper Bronze	x
Inspiration Collection	101-Titanium White	x	102-Titanium Black	x	103-Metallic Grey	x	104-Metallic Copper	x
	105-Slate Grey	x	106-Charcoal Grey	x	108-Autumn Blue	x		

ORDER FORM

POLYMAC AXES CORNER

Description	Product code	Pattern number	Code color	Qt./box 4 panels
Polymac Axes Corner 12'' x 12'', 22 g	SPCA1G22.12	No1		
Polymac Axes Corner 12'' x 12'', 22 g	SPCA2G22.12	No4		
Polymac Axes Corner 12'' x 12'', 22 g	SPCA3G22.12	No5		
Polymac Axes Corner 12'' x 12'', 22 g	SPCA4G22.12	No7		
Polymac Axes Corner 12'' x 12'', 22 g	SPCAMG22.12	Mix (all 4 No)		

SPECIFICATIONS | POLYMAC AXES CORNER 12'' X 12''

Length 12 in (304.8 mm)	Width 12 in (304.8 mm)	Depth 1 in (25.4 mm)	Box 4 panel (12 x 12 in), 8 ft ² (0.75 m ²)
---------------------------	--------------------------	------------------------	--

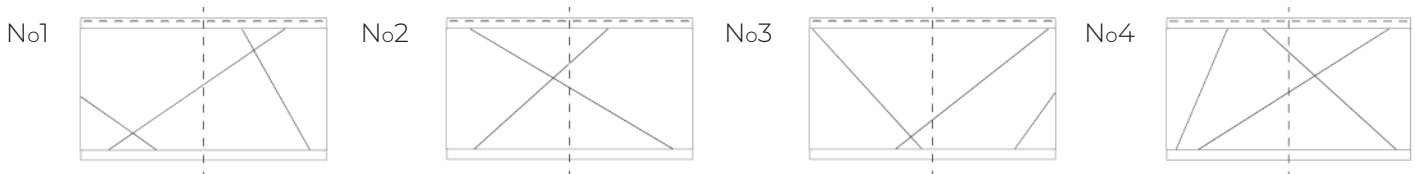

Description	Product code	Pattern number	Code color	Qt./box 4 panels
Polymac Axes Corner 20'' x 12'', 22 g	SPCA1G22.20	No1		
Polymac Axes Corner 20'' x 12'', 22 g	SPCA2G22.20	No4		
Polymac Axes Corner 20'' x 12'', 22 g	SPCA3G22.20	No5		
Polymac Axes Corner 20'' x 12'', 22 g	SPCA4G22.20	No8		
Polymac Axes Corner 20'' x 12'', 22 g	SPCAMG22.20	Mix (all 8 No)		

SPECIFICATIONS | POLYMAC CORNER AXES 20'' X 12''

Length 20 in (508 mm)	Width 12 in (304.8 mm)	Depth 1 in (25.4 mm)	Box 4 panels (12 x 12 in), 13.33 ft ² (1.25 m ²)
-------------------------	--------------------------	------------------------	---

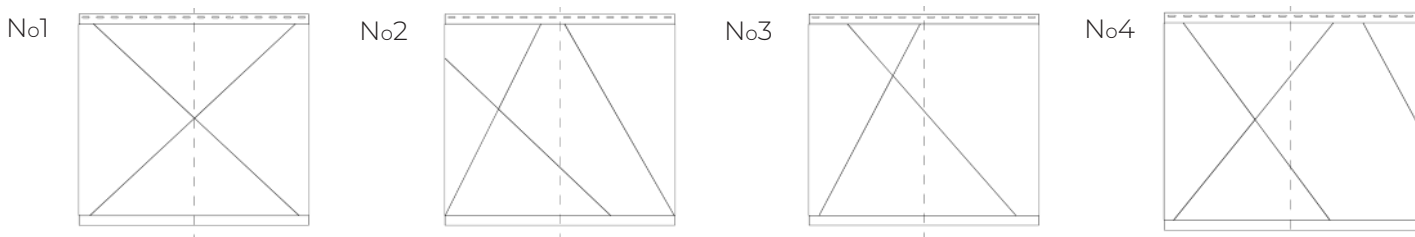

* Dotted lines on the drawings indicate the corner bending location

Collection	Color Code	22 g	22 g	22 g	22 g			
Signature Collection	202-Anthracite	x	203-Brushed Zinc	x	204-Smoky Quartz	x	205-Copper Bronze	x
Inspiration Collection	101-Titanium White	x	102-Titanium Black	x	103-Metallic Grey	x	104-Metallic Copper	x
	105-Slate Grey	x	106-Charcoal Grey	x	108-Autumn Blue	x		