

Project leader/ Chargé de projet:
EP

Part number /No. de pièce:
CORRIGATED MS380

Part name /Non de la pièce:
**CORRIGATED MS 380/
CORRIGUÉ MS 380**

Designer:
MM

Paint system/Système peinture:
**TEXTURAL III,TEXTURAL IV,
PERSPECTRA PLUS**

Material/Matière:
24, 26 gauge/jauge

Nominal thickness /Épaisseur nominale:
STEEL / ACIER

Revisions/Révision

REV.	DESCRIPTION
A	Original
-	-
-	-
-	-
-	-

Update/mise à jour:
14/06/2018



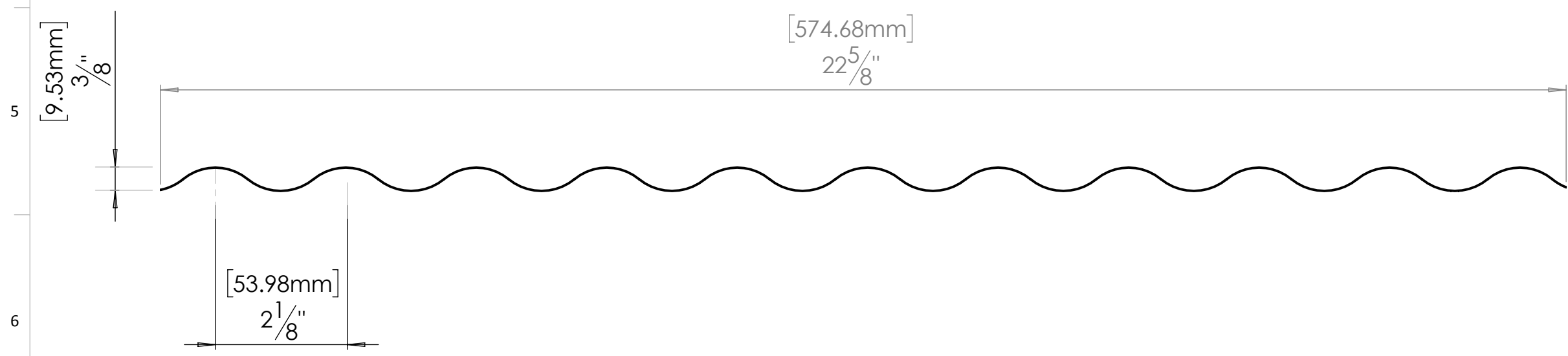
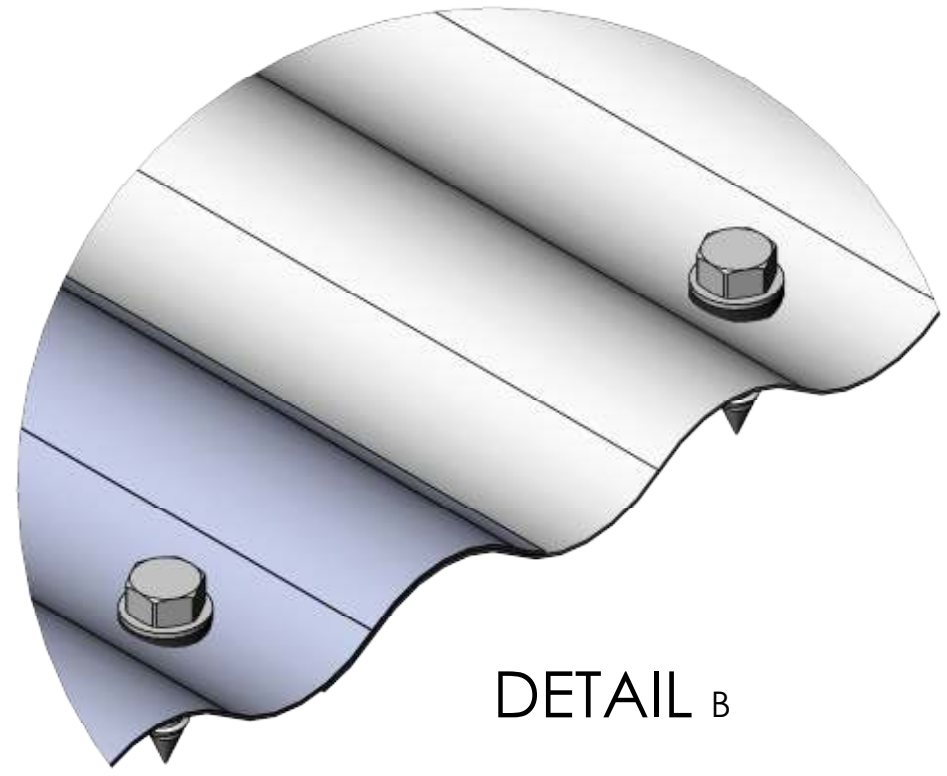
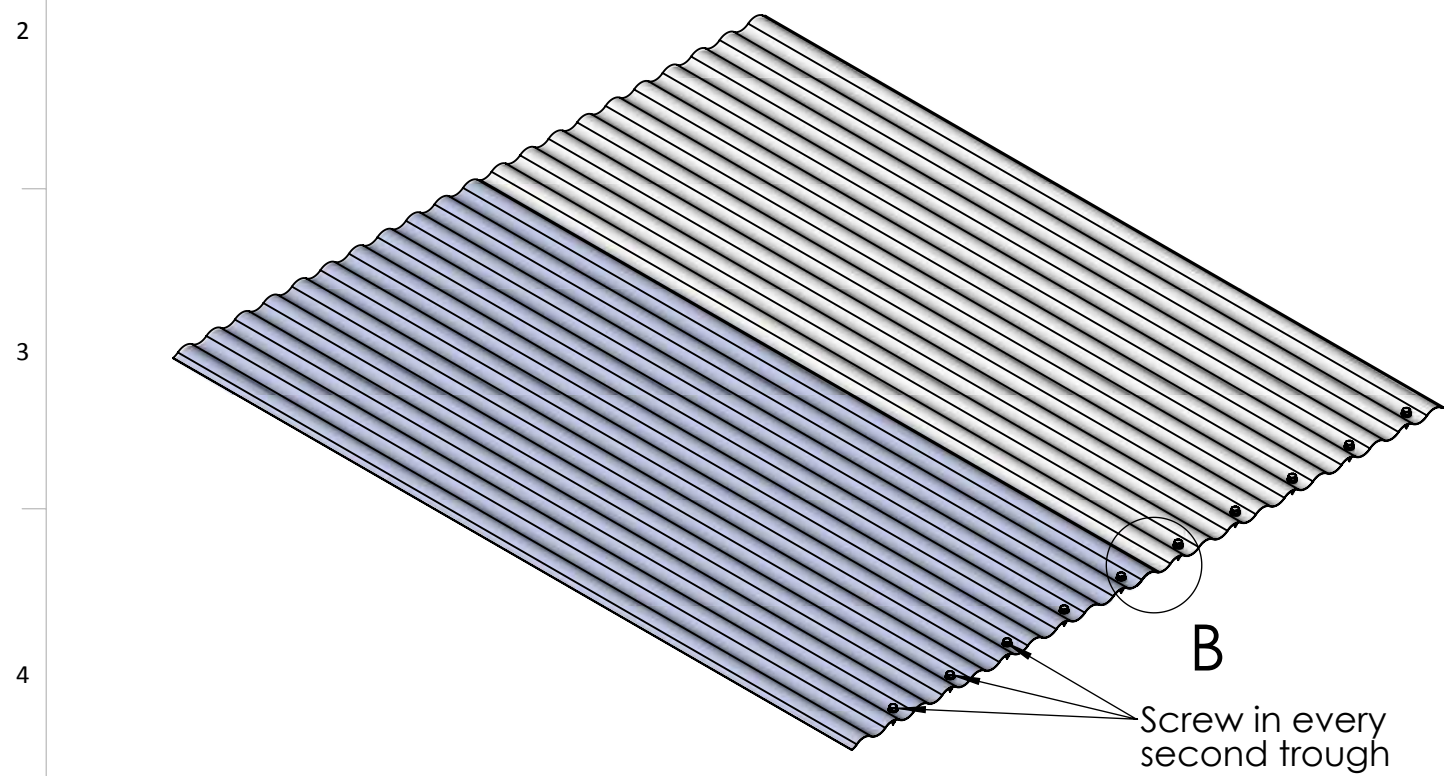
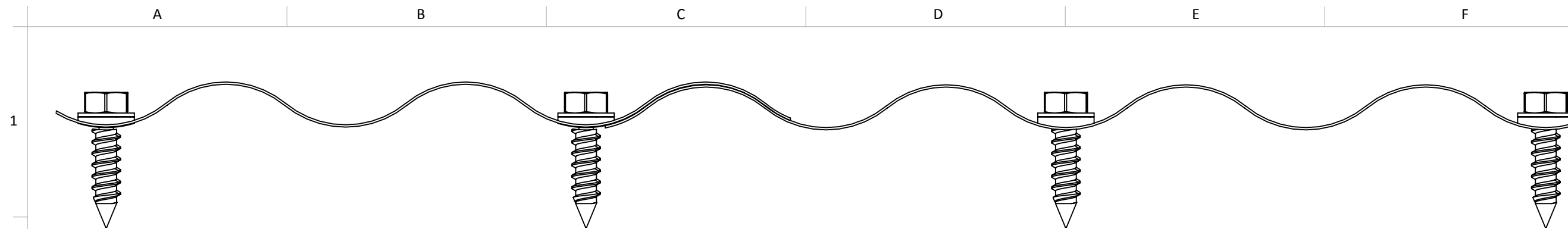

Project leader/ Chargé de projet:
EP

Part number /No. de pièce:
CORRIGATED MS 380

Part name /Non de la pièce:
**CORRIGATED MS 380/
 CORRIGUÉ MS 380**

Designer:
MM

Paint system/Système peinture:
**TEXTURAL III,TEXTURAL IV,
 PERSPECTRA PLUS**

Material/Matière:
24, 26 gauge/jauge

Nominal thickness /Épaisseur nominale:
STEEL / ACIER

Revisions/Révision

REV.	DESCRIPTION
A	Original
-	-
-	-
-	-
-	-

Update/mise à jour:
14/06/2018

